

Note 5-1: This pin (CS#) is the chip select input connecting to the MCU. enabled for MCU communication only when CS# is pulled LOW. The chip is
 Note 5-2: This pin is (D/C#) Data/Command control pin connecting to the MCU in 4-wire SPI mode. When the pin is pulled HIGH, the data at SDA will be interpreted as data. When the pin is pulled LOW, the data at SDA will be interpreted as command.
 Note 5-3: This pin (RES#) is reset signal input. The Reset is active low.
 Note 5-4: This pin is Busy state output pin. When Busy is High, the operation of chip should not be interrupted, command should not be sent. The chip would put Busy pin High when -Outputting display waveform -Communicating with digital temperature sensor
 Note 5-5: Bus interface selection pin
 LOW: 4-lines serial peripheral interface(SPI) - 8 bits SPI
 HIGH: 3- lines serial peripheral interface(SPI) - 9 bits SPI

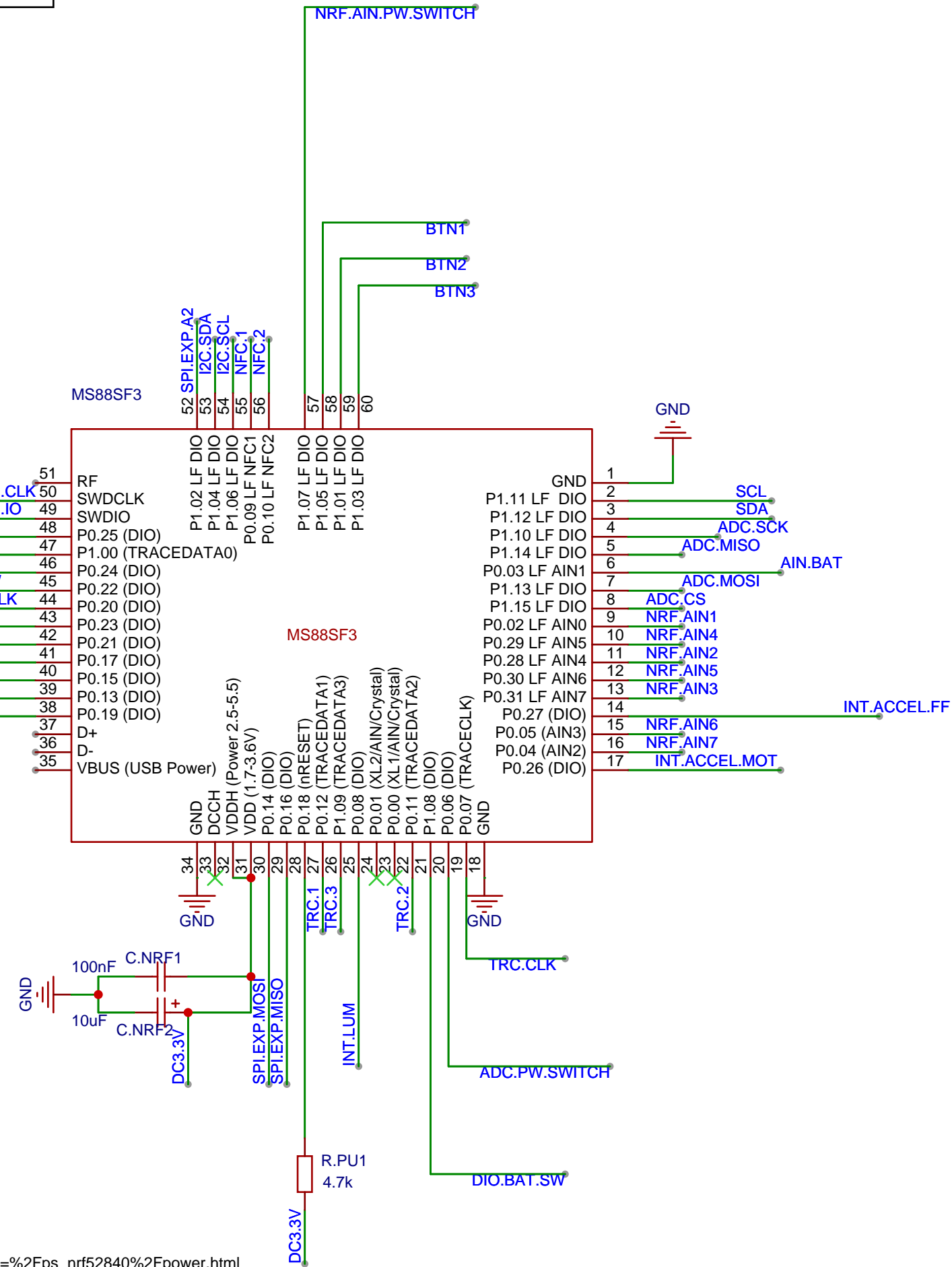

https://infocenter.nordicsemi.com/index.jsp?topic=%2Fps_nrf52840%2Fpower.html
 The system enters Normal Voltage mode when the supply voltage is connected to both the VDD and VDDH pins (pin VDD shorted to pin VDDH).
 For the supply voltage range to connect to both VDD and VDDH pins, see parameter VDD.

Schematic	Sensor Hub Schematics		Update Date	2023-05-15	
			Create Date	2023-05-13	
Page	Main		Part Number	JLPCB-002	
Drawn	EasyEDA Pro		Sensor Hub 2		
Reviewed	EasyEDA Pro				
			VER	SIZE	PAGE 1 OF 11
			V0.1	A4	EasyEDA.com



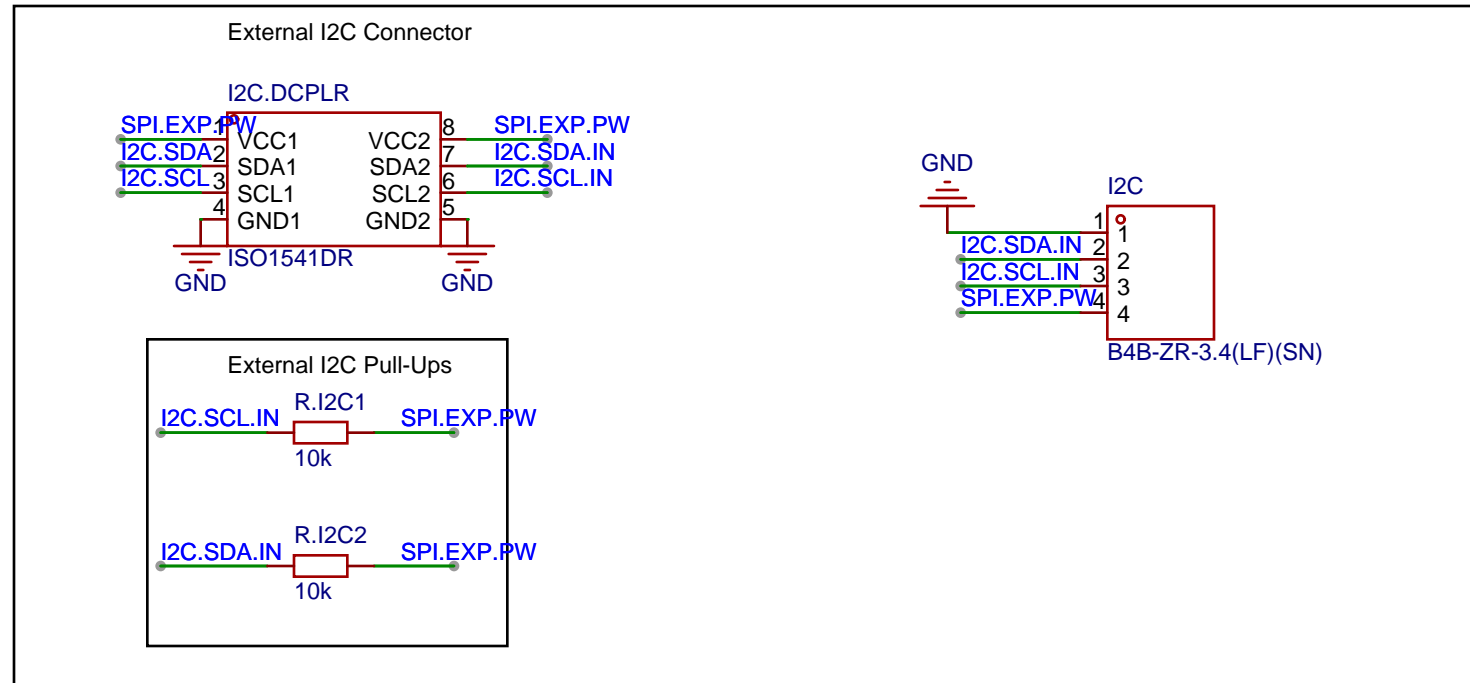

Schematic	Sensor Hub Schematics			Update Date	2023-05-13
				Create Date	2023-05-13
Page	I2C Connector			Part Number	JLCPCB-002
Drawn	EasyEDA Pro	Sensor Hub 2			
Reviewed	EasyEDA Pro				
		VER	SIZE	PAGE	2 OF 11
		V0.1	A4	EasyEDA.com	

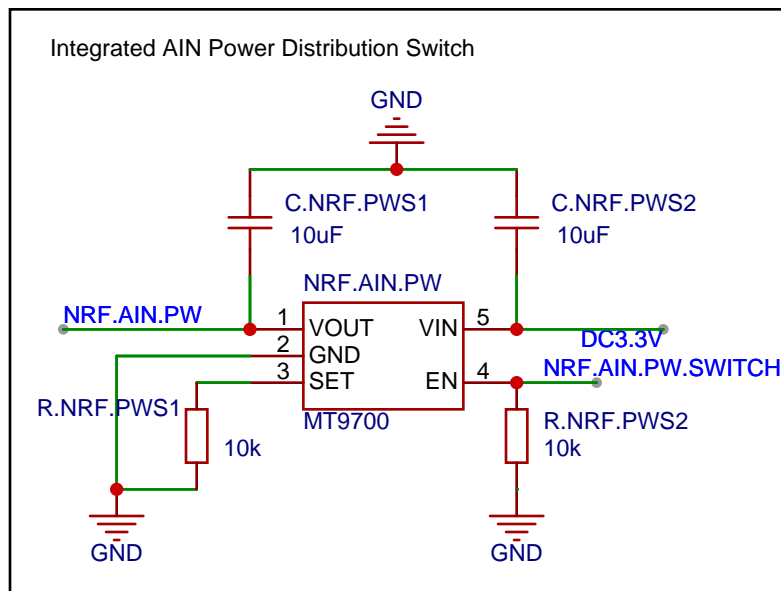
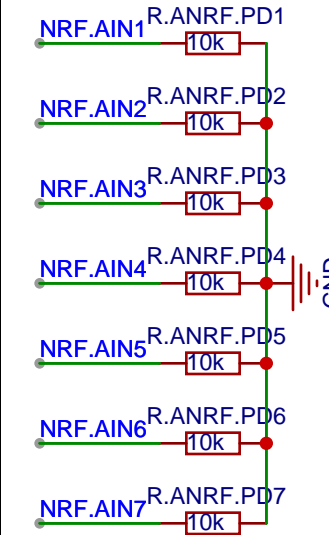
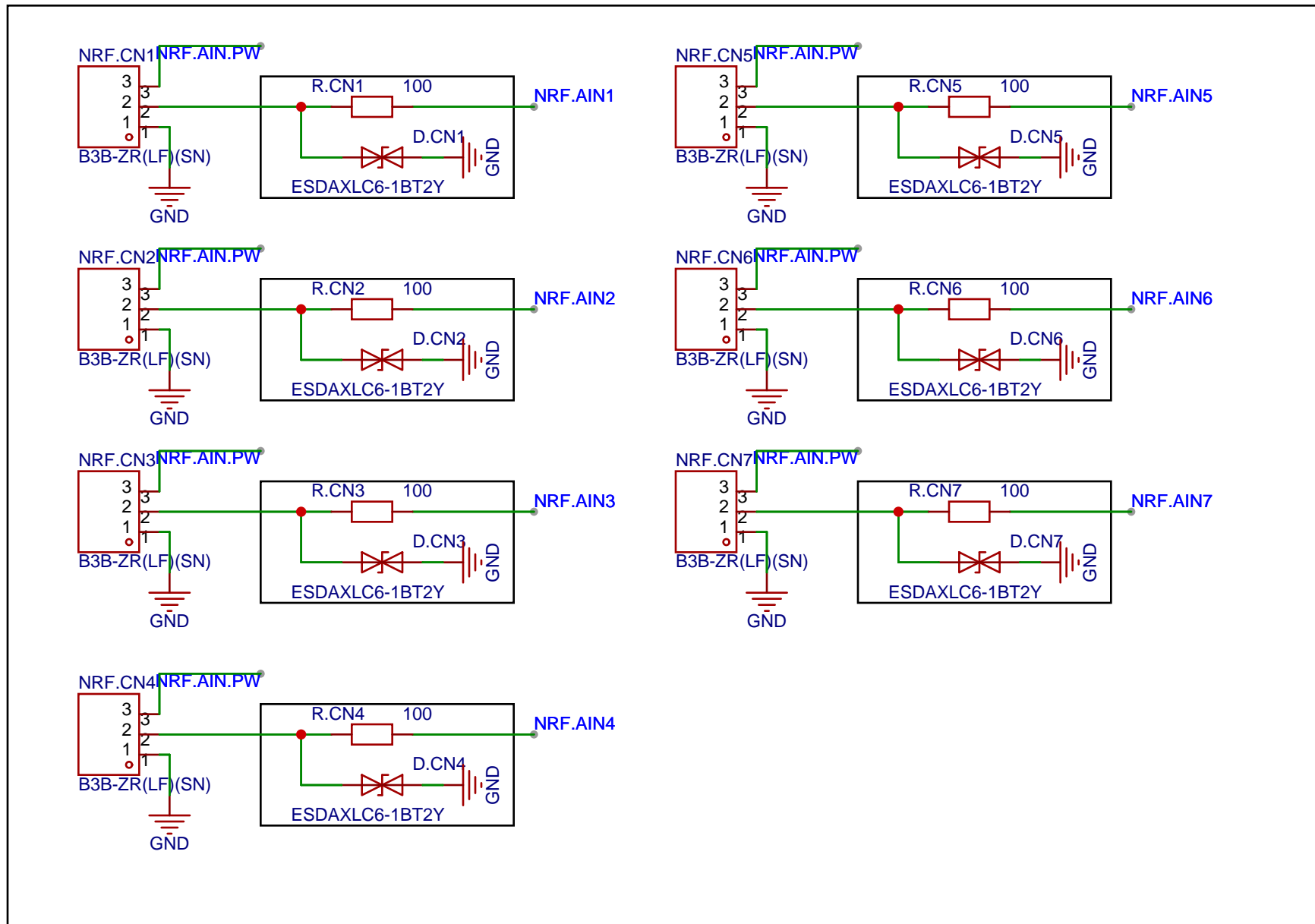

Schematic	Sensor Hub Schematics		Update Date	2023-05-14
			Create Date	2023-05-13
Page	NRF Analog Input Connectors		Part Number	JLPCB-002
Drawn	EasyEDA Pro	Sensor Hub 2		
Reviewed	EasyEDA Pro			
			VER	SIZE
			V0.1	A4
			PAGE	3 OF 11
			EasyEDA.com	

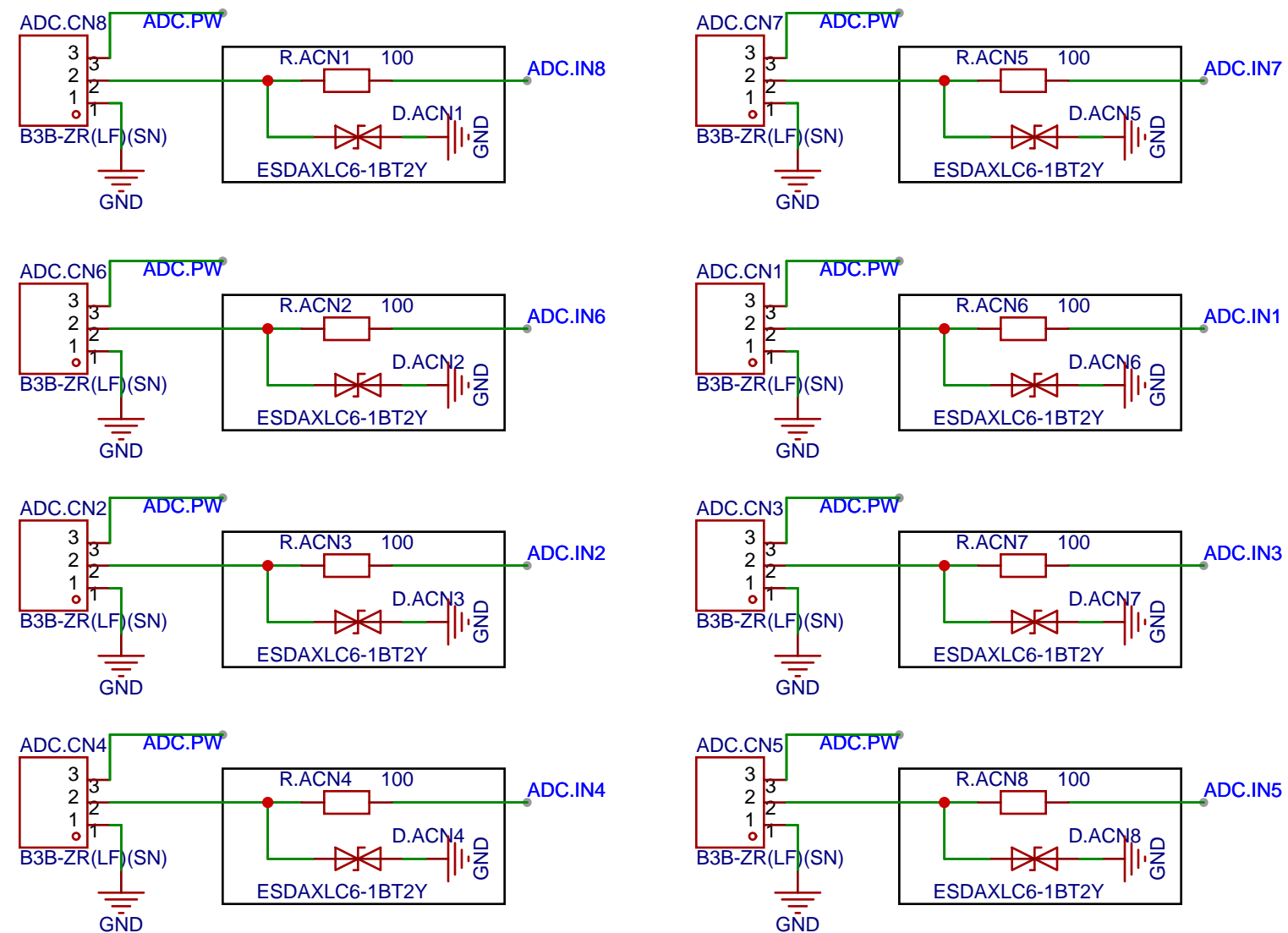

Schematic	Sensor Hub Schematics		Update Date	2023-05-15
			Create Date	2023-05-13
Page	ADC Analog Input Connectors		Part Number	JLPCB-002
Drawn	EasyEDA Pro	Sensor Hub 2		
Reviewed	EasyEDA Pro			
		VER	SIZE	PAGE 4 OF 11
		V0.1	A4	EasyEDA.com

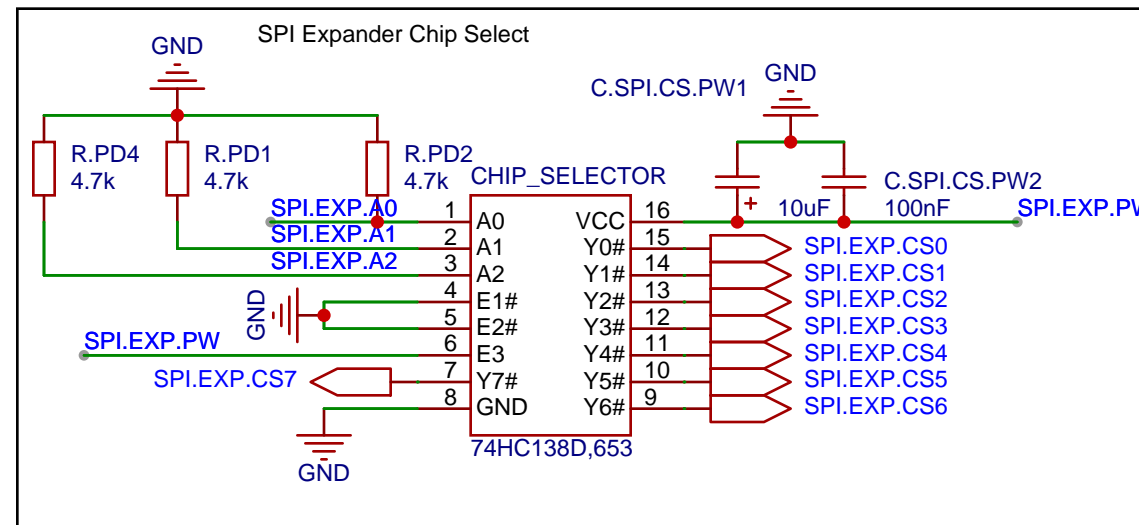
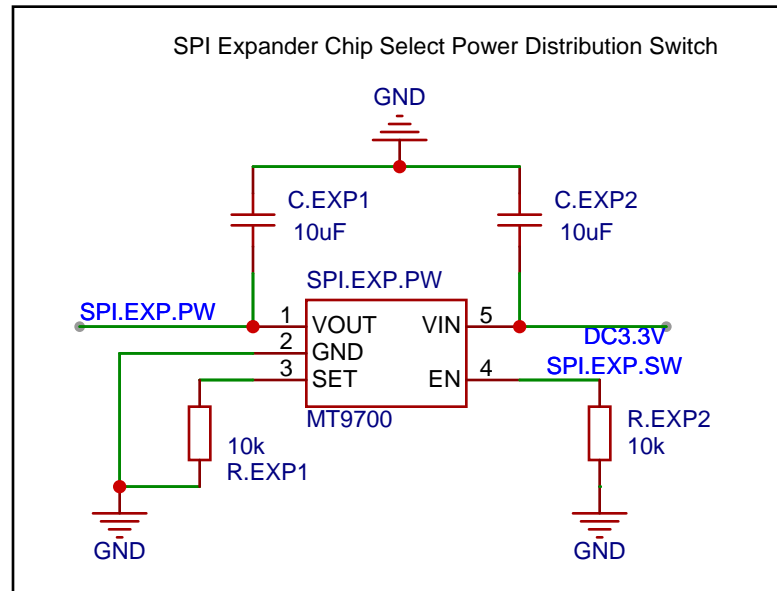

Schematic	Sensor Hub Schematics		Update Date	2023-05-15
			Create Date	2023-05-13
Page	SPI Expander		Part Number	JLPCB-002
Drawn	EasyEDA Pro	Sensor Hub 2		
Reviewed	EasyEDA Pro			
		VER	SIZE	PAGE 5 OF 11
		V0.1	A4	EasyEDA.com

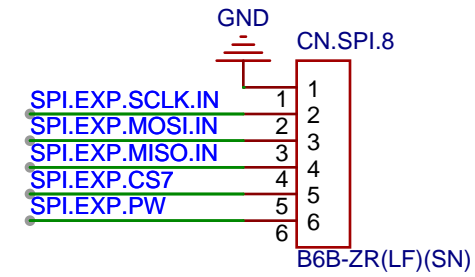
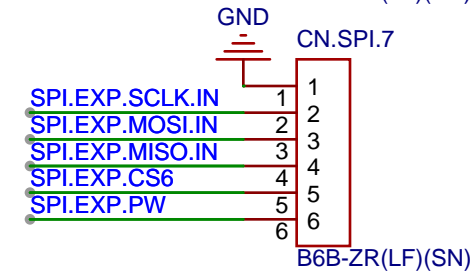
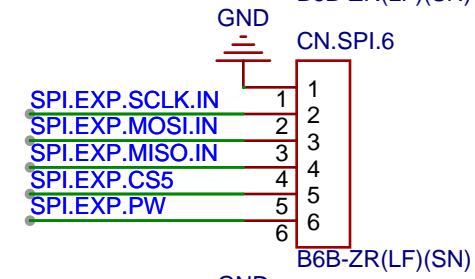
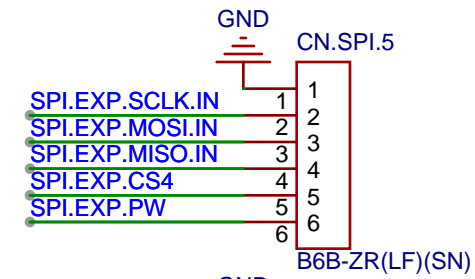
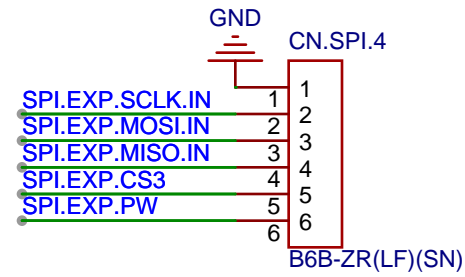
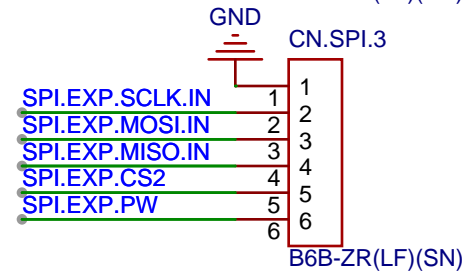
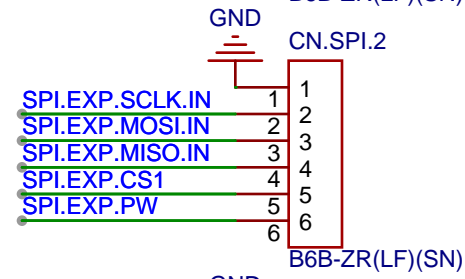
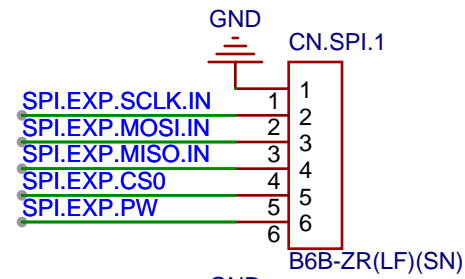
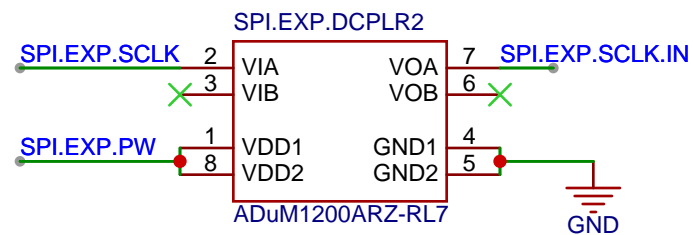
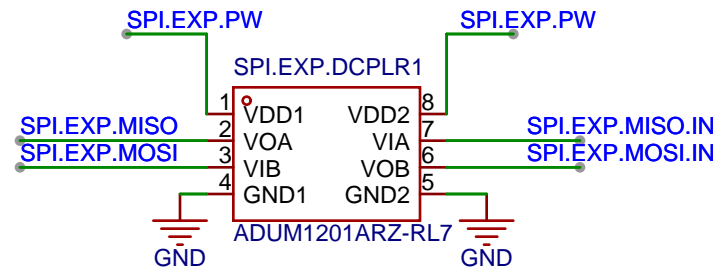

Schematic	Sensor Hub Schematics			Update Date	2023-05-15
				Create Date	2023-05-13
Page	SPI Expander Connectors			Part Number	JLCPCB-002
Drawn	EasyEDA Pro	Sensor Hub 2			
Reviewed	EasyEDA Pro				
		VER	SIZE	PAGE	6 OF 11
		V0.1	A4	EasyEDA.com	

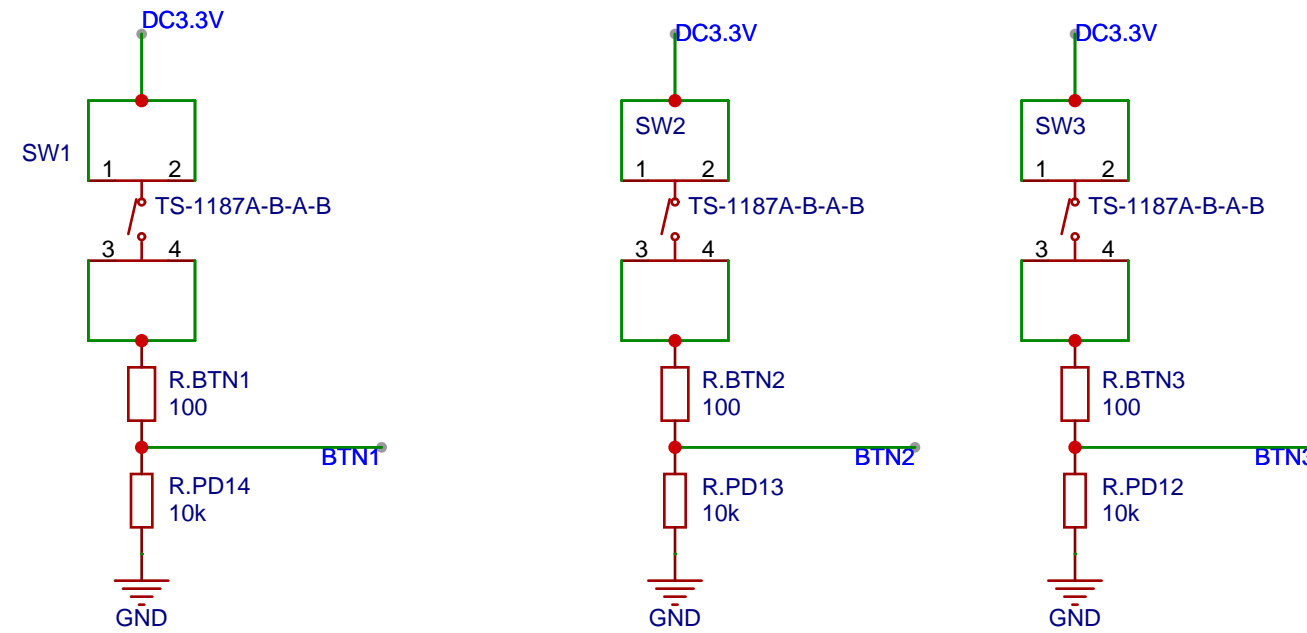

Schematic	Sensor Hub Schematics			Update Date	2023-05-14
				Create Date	2023-05-13
Page	Buttons			Part Number	JLPCB-002
Drawn	EasyEDA Pro	Sensor Hub 2			
Reviewed	EasyEDA Pro				
		VER	SIZE	PAGE	7 OF 11
		V0.1	A4	EasyEDA.com	

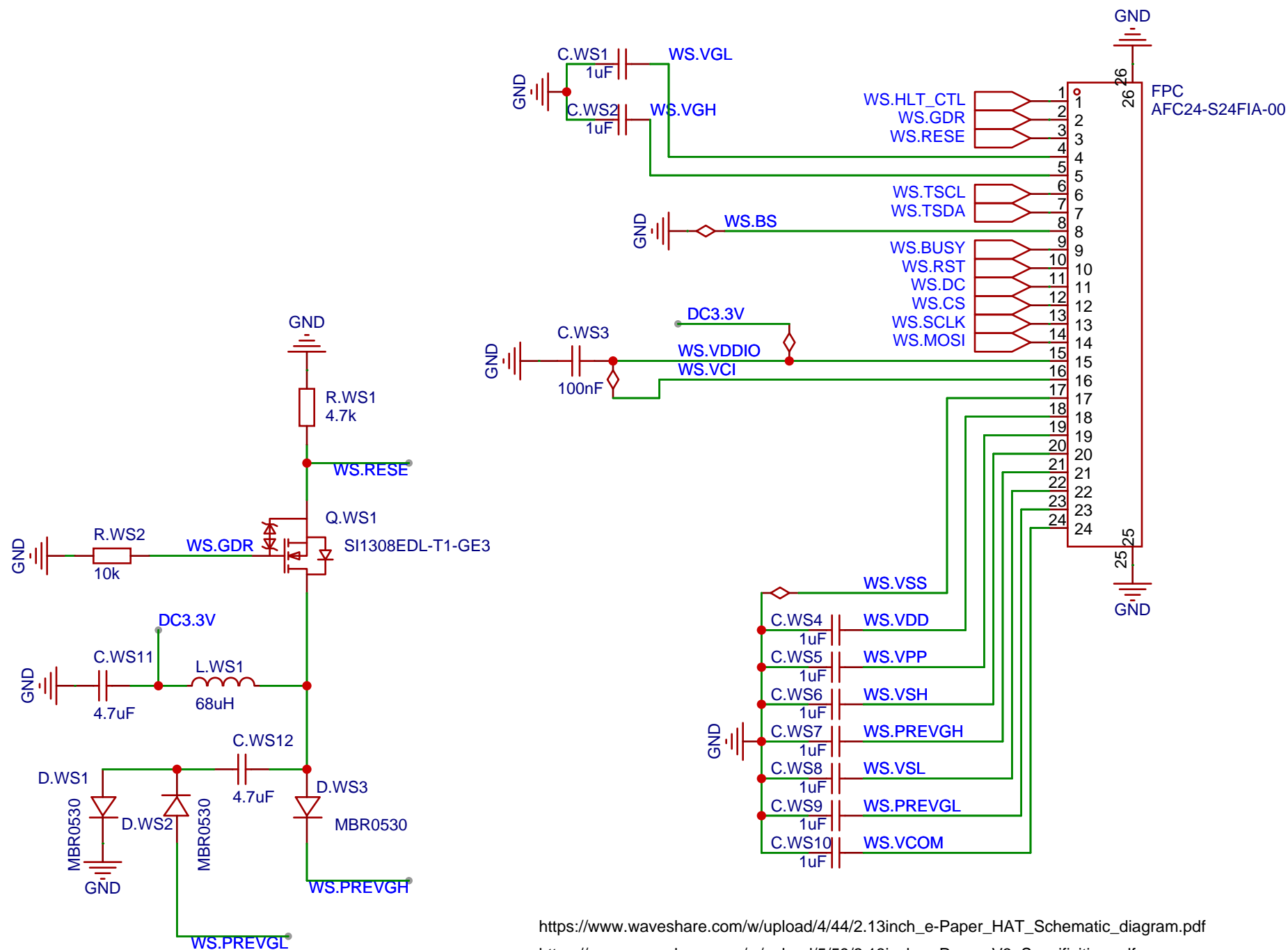

https://www.waveshare.com/w/upload/4/44/2.13inch_e-Paper_HAT_Schematic_diagram.pdf
https://www.waveshare.com/w/upload/5/59/2.13inch_e-Paper_V3_Specification.pdf

Note 5-1: This pin (CS#) is the chip select input connecting to the MCU. enabled for MCU communication only when CS# is pulled LOW.
The chip is
Note 5-2: This pin is (D/C#) Data/Command control pin connecting to the MCU in 4-wire SPI mode. When the pin is pulled HIGH, the data at SDA will be interpreted as data. When the pin is pulled LOW, the data at SDA will be interpreted as command.
Note 5-3: This pin (RES#) is reset signal input. The Reset is active low.
Note 5-4: This pin is Busy state output pin. When Busy is High, the operation of chip should not be interrupted, command should not be sent. The chip would put Busy pin High when -Outputting display waveform -Communicating with digital temperature sensor
Note 5-5: Bus interface selection pin
LOW: 4-lines serial peripheral interface(SPI) - 8 bits SPI

Schematic	Sensor Hub Schematics		Update Date	2023-05-14
			Create Date	2023-05-13
Page	E-Paper Display		Part Number	JLPCB-002
Drawn	EasyEDA Pro	Sensor Hub 2		
Reviewed	EasyEDA Pro			
		VER	SIZE	PAGE 8 OF 11
		V0.1	A4	EasyEDA.com

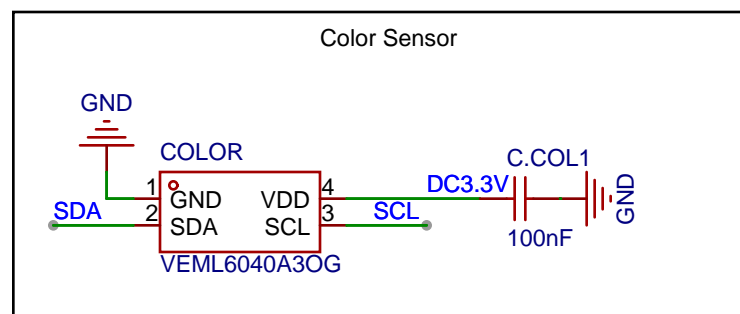
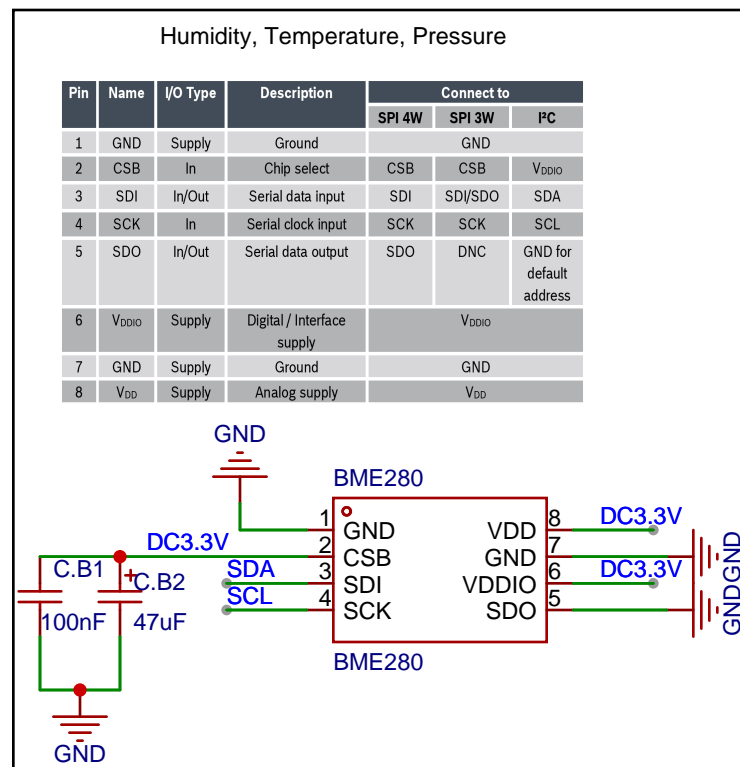
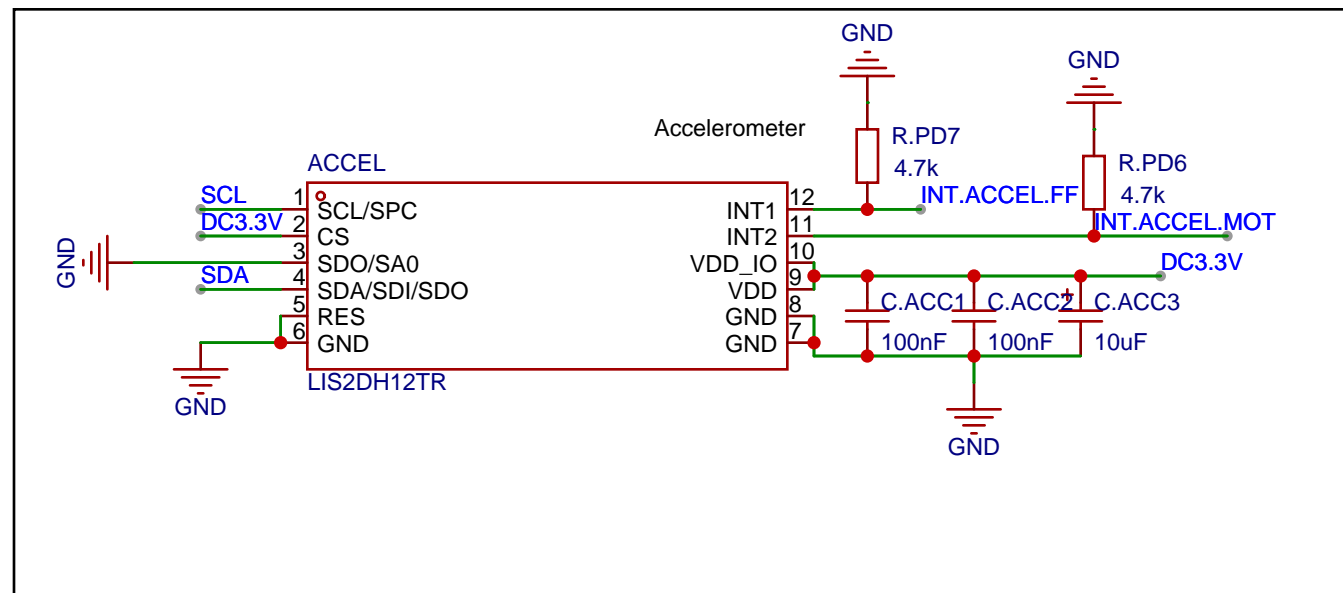
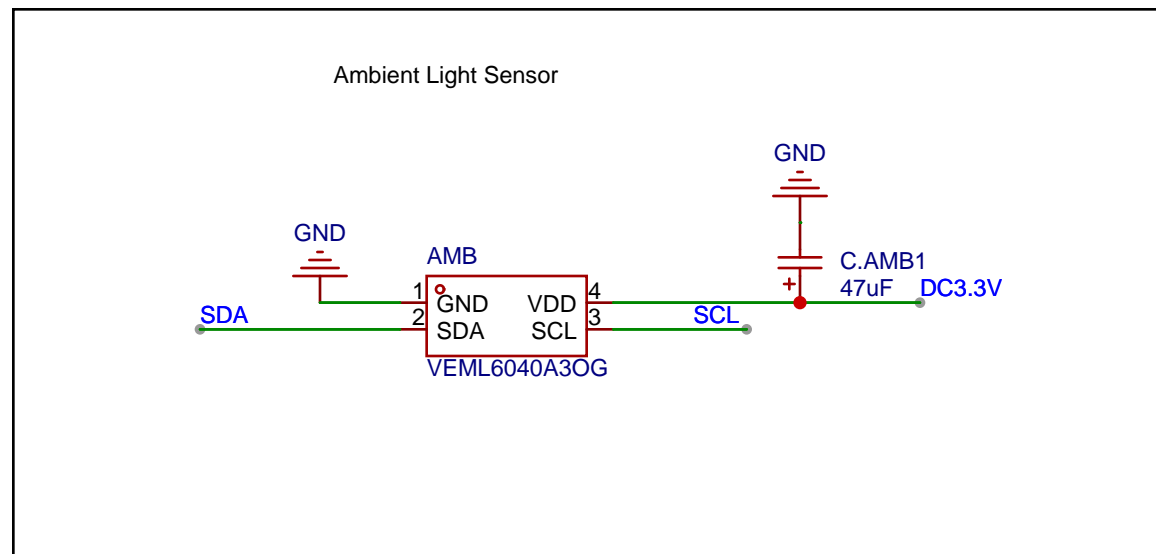

Schematic	Sensor Hub Schematics		Update Date	2023-05-15
			Create Date	2023-05-13
Page	Sensors		Part Number	JLPCB-002
Drawn	EasyEDA Pro	Sensor Hub 2		
Reviewed	EasyEDA Pro			
		VER	SIZE	PAGE 9 OF 11
		V0.1	A4	EasyEDA.com

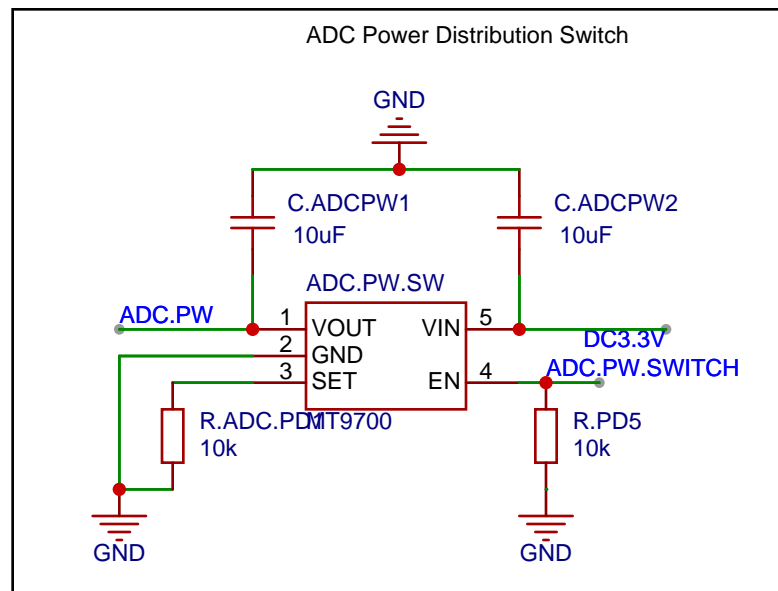
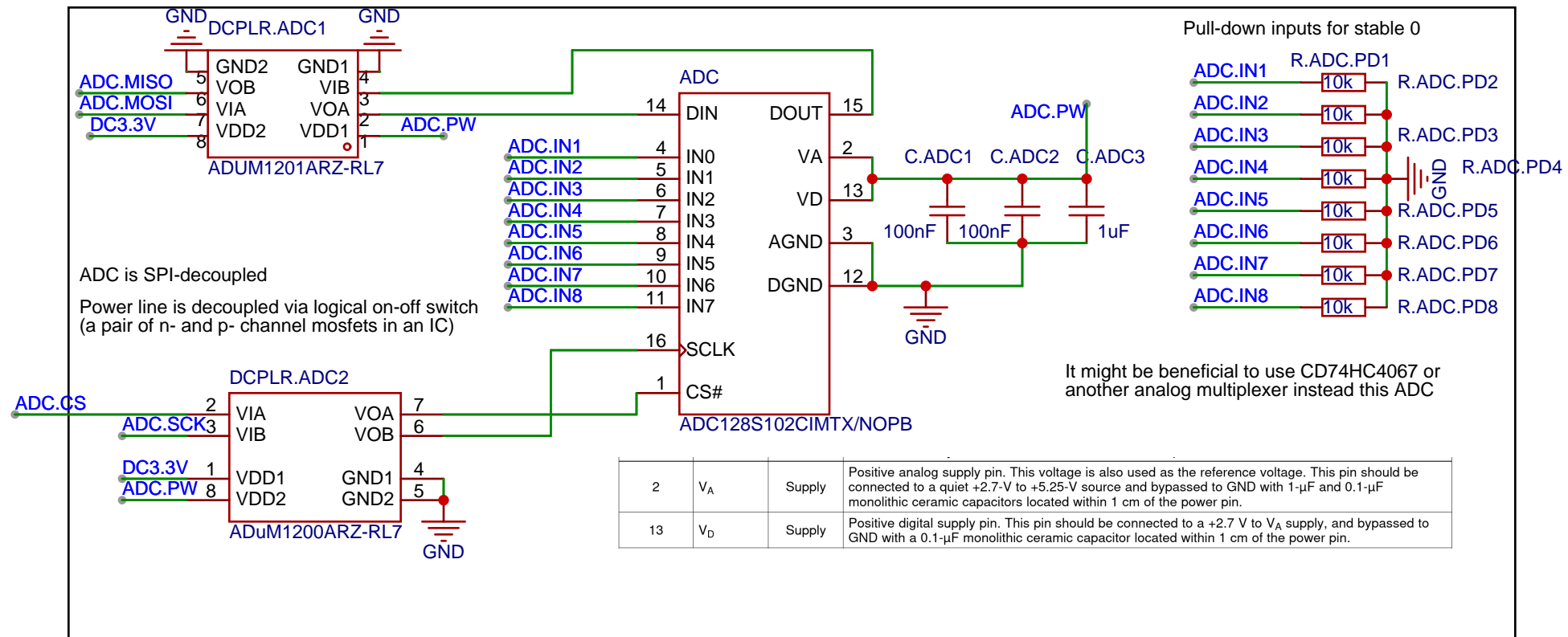

Schematic	Sensor Hub Schematics		Update Date	2023-05-15
			Create Date	2023-05-13
Page	ADC		Part Number	JLPCB-002
Drawn	EasyEDA Pro	Sensor Hub 2		
Reviewed	EasyEDA Pro			
		VER	SIZE	PAGE 10 OF 11
		V0.1	A4	EasyEDA.com

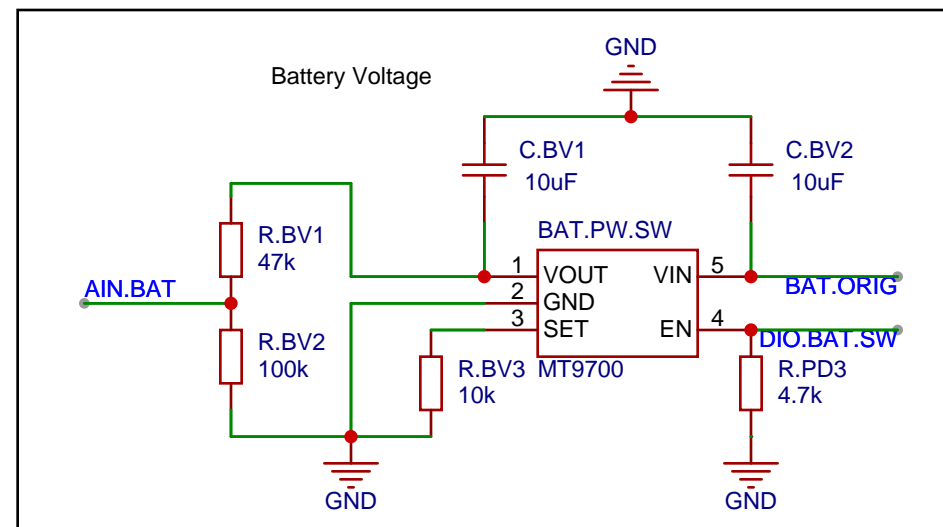
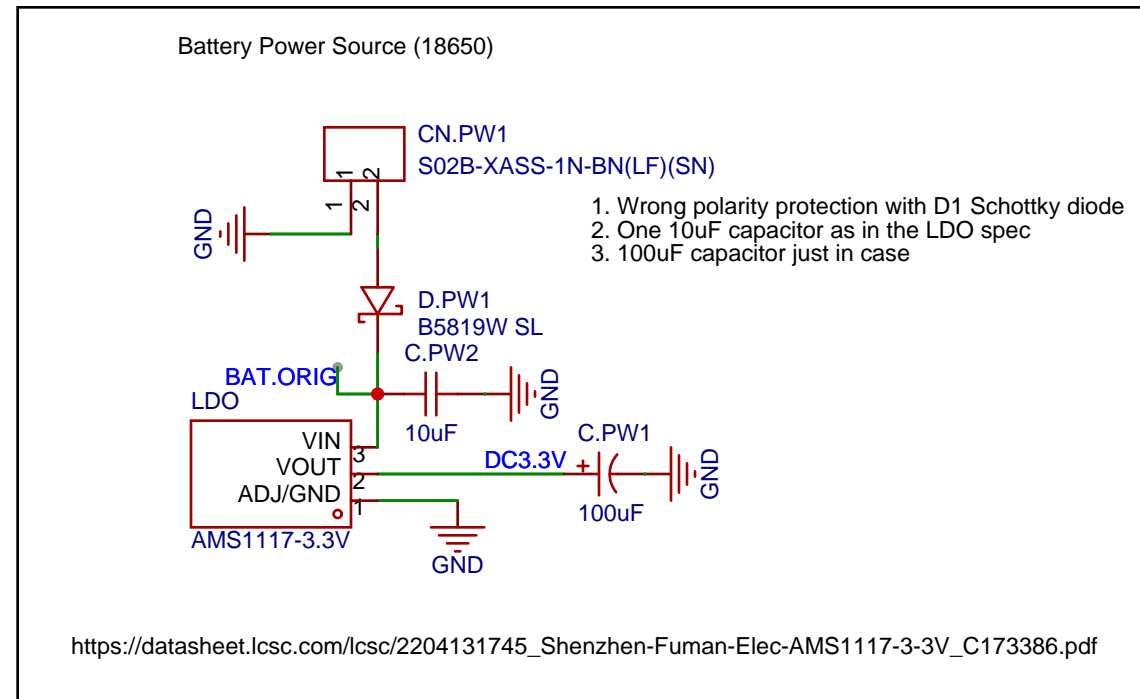

Schematic	Sensor Hub Schematics		Update Date	2023-05-14
			Create Date	2023-05-13
Page	Power		Part Number	JLPCB-002
Drawn	EasyEDA Pro	Sensor Hub 2		
Reviewed	EasyEDA Pro			
		VER	SIZE	PAGE 11 OF 11
		V0.1	A4	EasyEDA.com